

Prostal

**Model POT-WPE1
Outdoor Waterproof Enclosure
Product Datasheet**



www.prostal.com.tw

The **POT-WPE1 Waterproof Enclosure** is constructed from 304 stainless steel, ensuring durability and protection. The enclosure is fully waterproof, dustproof and anti-static. Made from 1.2mm thick stainless steel, it offers excellent pressure and corrosion resistance.

This enclosure is ideal for the outdoor installation of small electronic devices, including network communication equipment, power adapters, surge protectors, and small switches. It is widely used to protect outdoor electrical equipment such as security surveillance devices, telecommunication systems and traffic management equipment.

Features

- ◆ IP67 protection level for waterproof, dustproof and anti-static
- ◆ Excellent pressure and corrosion resistance
- ◆ Three installation ways for choices
- ◆ Ideal outdoor enclosure for small electronic devices

Dimension

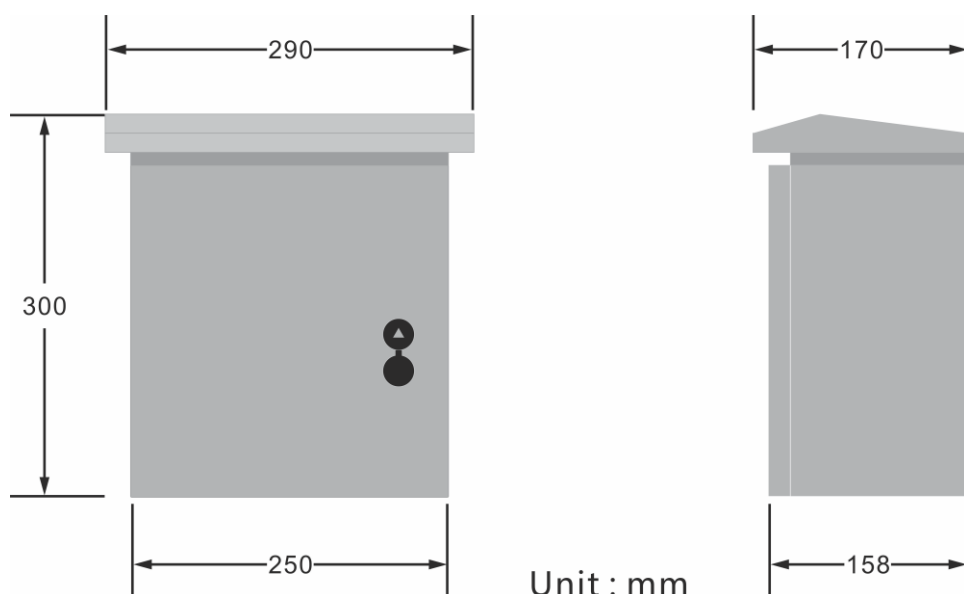

Note: Metal processing parts allow a tolerance of ± 3 mm.

Technical Parameter

Category	Description
Enclosure Material	Stainless Steel 304
Protection Level	IP67
Color	7035 Gray-White
External Dimensions (H×W×D)	300×250×158mm
Internal Dimensions (H×W×D)	230×240×130mm
Working Temperature	-40°C~60°C
Heat Dissipation Method	Side wall cooling fan (Optional)
Installation Method	Wall-mounted, pole-mounted, flat steel belt
Door Opening Method	Top opening, side opening
Weight	5.1Kg
Standard Accessories	35mm DIN-rail, grounding copper bar
Optional Accessories	Cooling fan, steel hook, metal screw and expansion bolt, power supply socket

Structure and Installation

The waterproof enclosure includes a 35mm DIN-rail and grounding copper bar. During installation, secure the product's mounting rail on the DIN rail. The input and output wires should be threaded through the cable entry hole at the bottom of the enclosure, and the waterproof plug should be fastened.

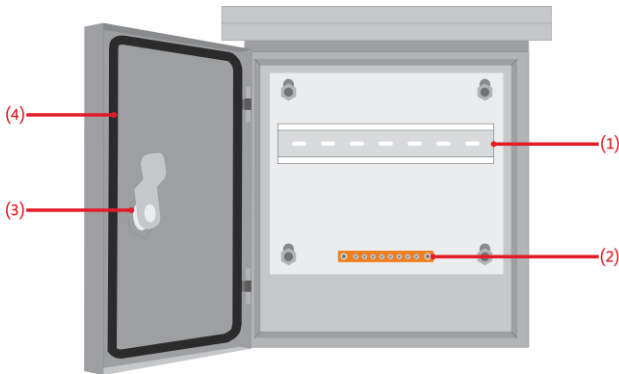

(1) DIN rail (2) Grounding copper bar (3) Latch (4) Sealing ring

Optional accessories



Power supply
Socket x 1



Cooling fan x 1



Steel hook x 2



Metal screw and
expansion bolt x 4